



*Photo may not represent actual product.*

## **Edelbrock Enforcer EFI Supercharger**

### **302-400 C.I.D. Small-Block Chevy**

**1986 and Earlier Style Heads: 1520, 1521, 15201, 15211, 15203, 15213**

**E-Tec and Vortec Style Heads: 1522, 1523, 15221, 15231, 15223, 15233**



# Edelbrock Enforcer EFI Supercharger System 302-400 C.I.D. Small-Block Chevrolet

## Installation Instructions

### INTRODUCTION

Thank you for purchasing the Edelbrock Dual-Quad Enforcer Supercharger for the 302-400 C.I.D. small-block Chevrolet engines. The Edelbrock Enforcer Supercharger utilizes Eaton's TVS2300 Supercharger rotors, which features a four lobe design with a full 160° of twist. This design offers quiet operation, maximum air flow, minimal temperature rise and the reliability for which Eaton is known. These rotors however, are merely the foundation of the system. The Edelbrock Supercharger is a complete system that maximizes efficiency and performance by minimizing air restriction into and out of the supercharger. As a result, the Enforcer supercharger maximizes airflow with minimum temperature increases and minimum power consumption. This Dual-Quad Enforcer Supercharger will accept standard 4150-style bolt pattern throttle bodies. Base supercharger systems will not include the throttle bodies, electronics, harness or injectors.

PART NUMBER	FINISH	APPLICATION	DESCRIPTION
1520	Satin	Small-Block Chevy 1986 and Earlier	Enforcer TVS2300 Supercharger, Intercooled, Dual-Quad, Does Not Include Throttle Bodies, Electronics, Harness & Injectors
1521	Satin		Enforcer TVS2300 Supercharger, Intercooled, Dual-Quad, Complete with Electronics
15201	Polished		Enforcer TVS2300 Supercharger, Intercooled, Dual-Quad, Does Not Include Throttle Bodies, Electronics, Harness & Injectors
15211	Polished		Enforcer TVS2300 Supercharger, Intercooled, Dual-Quad, Complete with Electronics
15203	Black		Enforcer TVS2300 Supercharger, Intercooled, Dual-Quad, Does Not Include Throttle Bodies, Electronics, Harness & Injectors
15213	Black		Enforcer TVS2300 Supercharger, Intercooled, Dual-Quad, Complete with Electronics
1522	Satin		E-Tec/Vortec Style Cylinder Heads
1523	Satin	Enforcer TVS2300 Supercharger, Intercooled, Dual-Quad, Complete with Electronics	
15221	Polished	Enforcer TVS2300 Supercharger, Intercooled, Dual-Quad, Does Not Include Throttle Bodies, Electronics, Harness & Injectors	
15231	Polished	Enforcer TVS2300 Supercharger, Intercooled, Dual-Quad, Complete with Electronics	
15223	Black	Enforcer TVS2300 Supercharger, Intercooled, Dual-Quad, Does Not Include Throttle Bodies, Electronics, Harness & Injectors	
15233	Black	Enforcer TVS2300 Supercharger, Intercooled, Dual-Quad, Complete with Electronics	

The Edelbrock Enforcer supercharger is intended for 302-400 c.i.d. small block Chevrolets equipped with long water pumps and stock style bracketry. It's designed to utilize the factory accessory drive belts, in conjunction with, the secondary 10 rib supercharger pulley drive system.

As with any universal power add-ons, actual power outputs will vary depending on the application. Below is a general baseline with actual power numbers from testing. Please note that this is just a guideline used for reference only. Actual power and boost output will vary depending on your application.

SPECIFICATIONS			
<b>Displacement</b>	350 C.I.D	<b>Compression</b>	9.5 : 1
<b>Block</b>	GM 4 Bolt Main w/ 1-Piece Rear Seal	<b>Pulley Size</b>	4"
<b>Cylinder Heads</b>	Edelbrock E-Tec 200 #60985	<b>Boost PSI</b>	*5 PSI (+1-1.5 in upper RPM)
<b>Camshaft</b>	Edelbrock Rollin' Thunder #2205	<b>Horsepower</b>	*519 hp
<b>Throttle Body</b>	Dual 1,000 CFM #38283	<b>Torque</b>	*507 ft-lbs
*Actual horsepower, torque and boost numbers will vary depending on application.			



## Edelbrock Enforcer EFI Supercharger System 302-400 C.I.D. Small-Block Chevrolet

### Installation Instructions

#### TOOLS AND EQUIPMENT:

- Box and Open End Wrenches
- Socket Set
- Distributor Wrench
- Pliers
- Screw Drivers (Regular and Phillips)
- Torque Wrench
- Gasket Scraper
- Timing Light
- Vacuum Gauge
- Rags
- Water Bucket
- Paper and Pencil
- Masking Tape

#### ADDITIONAL MATERIALS REQUIRED:

- High Volume Fuel Pump
  - #3594 - 67 gph @ 45 psi, 3/8" hose barb inlet/outlet
  - #1790 - 80 gph @ 45 psi, -10 AN inlet/outlet
  - #1794 - 120 gph @45 psi, -12 AN inlet/outlet
- Fuel Pressure Regulator w/ Boost Reference
  - #3584 - For Pro-Flo 2 and Pro-Flo XT systems
  - #1728 - 180 GPH w/ -6 AN inlets/bypass
  - #1729 - 180 GPH w/ -10 AN inlets and -6 AN bypass
- Fuel Fittings and Fuel Lines
- Low Temperature Radiator
  - #15405: Full Face Universal Fit
  - #15406: Compact Single
- Dual-Quad Air Cleaner
- Spark Plugs *2-3 heat ranges colder than plugs currently using in your naturally aspirated engine*
- Throttle Brackets and Hardware
- Fuel Pump Block-off Plate
- Edelbrock Gasgacinch (#9300)
- Silicone
- Thread Sealer
- Loctite™ - Red, Blue, or Equivalent
- Radiator Coolant

## IMPORTANT WARNINGS

**Before beginning the installation, use the enclosed checklist to verify that all components are present in the box. Then inspect each component for damage that may have occurred in transit. If any parts are missing or damaged, contact Edelbrock Technical Support (800-416-8628), not your parts distributor.**



**WARNING:** Installation of this supercharger will result in a significant change to the performance characteristics of your vehicle. It is highly recommended that you take some time to familiarize yourself with the added power, and how it is delivered, in a controlled environment. Take extra care on wet and slippery roads, as the rear tires will be more likely to lose traction, with the added power.

**WARNING:** Exposed fuel and oil will be present during this installation. When working around gasoline and/or oil, always work in a well ventilated area, and keep all open flames, sparks and other sources of ignition away from the work areas. Failure to do so can result in a fire and/or explosion

**Proper installation is the responsibility of the installer. Improper installation will void all manufacturer's standard warranties and may result in poor performance and engine or vehicle damage.**

Successful operation of the engine with this supercharger kit requires a working knowledge of the set-up and tuning of an engine. This supercharger kit is capable of supporting over 500 HP. Aftermarket pistons, connecting rods, and valves are recommended to ensure engine durability. See the "Boost and Ignition Timing" section in this manual for further information. The valve lash or lifter preload should be properly adjusted. If the valves are not properly seating, or the valve lash is not properly adjusted, the increased temperatures created by the increased power output could accelerate valve seat wear and cause burnt valves. If for any reason your engine has oil pressure that is below the acceptable service limits as specified in the Factory Service Manual, this problem should be corrected before installing this supercharger kit.

**THIS EDELBROCK ENFORCER SUPERCHARGER WILL NOT WORK WITH HIGH ENERGY IGNITION (HEI) DISTRIBUTORS**

**FUEL PUMP REQUIREMENTS:** This supercharger requires significantly more fuel to properly operate when compared to naturally aspirated applications. A High Volume Fuel Pump is required. Please select one properly rated for your application (See page 3).

**AFTER INSTALLATION, BEFORE STARTING THE VEHICLE:** The use of colder spark plugs are strongly recommend when installing a supercharger. In our testing, we used Champion RC9YC spark plugs, which are 2-3 heat ranges colder than the spark plugs used in a naturally aspirated engine. Any manufacturer's plugs that match the correct plug configuration for your application will be adequate.

**HOOD CLEARANCE:** This supercharger is tall by design. An aftermarket hood and/or modifications to the hood may be required. Please make modifications before operating the vehicle.



**91 octane or higher gasoline is required at all times. If your vehicle has been filled with anything less, it must be run until almost dry and refilled with 91 or higher octane gasoline twice prior to installation.**

**Failure to use the required 91 octane gasoline or higher could permanently damage your engine. Any failures associated with not using premium 91 octane gasoline or higher, will be ineligible for warranty repairs.**

**It is recommended that you check the Edelbrock Tech Center Website for any updates to this installation manual. Please refer to the lower left hand footer to verify that you have the latest revision of this installation manual before beginning the installation.**

**Tech Center: [http://www.edelbrock.com/automotive\\_new/misc/tech\\_center/install/index.php](http://www.edelbrock.com/automotive_new/misc/tech_center/install/index.php)**

**Edelbrock Authorized Installer Disclaimer**

Authorized installers of Edelbrock products are independent companies over which Edelbrock has no right of control. Edelbrock LLC makes no claims regarding the abilities, expertise or competency of individual employees of any authorized installer. Each authorized installer is an independent company and makes its own independent judgments. Edelbrock LLC specifically disclaims any responsibility to any party including third parties for the actions, or the failure to act, of individuals, agents or a company authorized in the installation of Edelbrock LLC products.

**FEAD KIT CONTENT**

(parts not to scale)

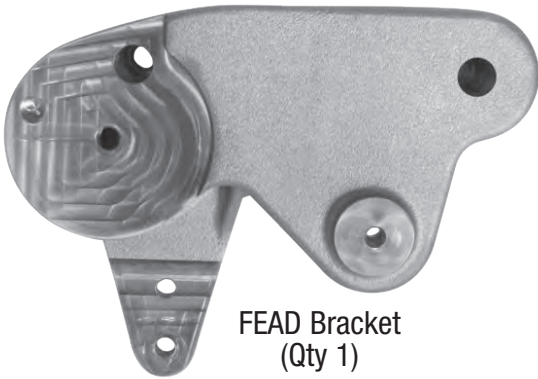

FEAD Bracket  
(Qty 1)



Waterneck Gasket  
(Qty 1)



Idler Pulley  
(Qty 1)

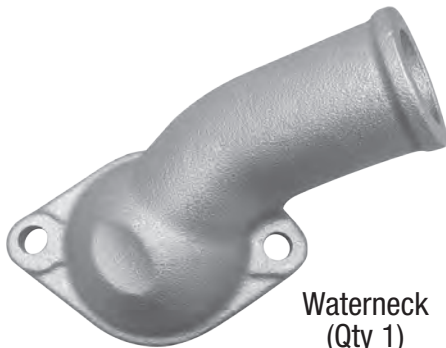

Waterneck  
(Qty 1)



Tensioner  
(Qty 1)



FEAD Spacer  
(Qty 1)



Alternator Bracket  
(Qty 1)

# INTERCOOLER KIT

(parts not to scale)



Recovery Tank w/ Cap



Water Pump



Recovery Tank Bracket



Water Pump Bracket



3/4" Hose (Qty 7')



Water Pump Bracket Strap

## HARDWARE BAG 1

(parts not to scale)



Hex Head 3/8-24 x 3.75"  
(Qty 3)



Hex Head 7/16-20 x 2.75"  
(Qty 1)



Hex Flange 3/8-16 x 3.25"  
(Qty 1)



Hex Flange 5/16-18 x 2.00"  
(Qty 1)

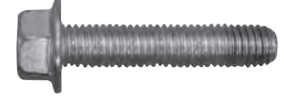

Hex Flange 5/16-18 x 1.25"  
(Qty 1)



Socket Head 5/16-18 x 3.5"  
(Qty 2)



Set Screw 5/16-18  
(Qty 1)

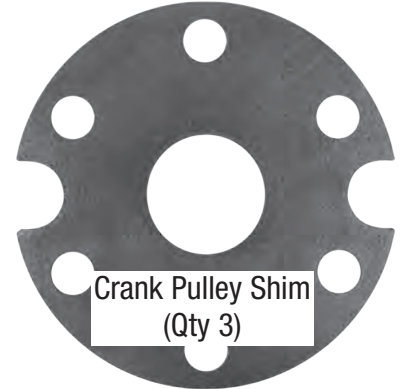

Crank Pulley Shim  
(Qty 3)



Washer 7/16"  
(Qty 1)



Washer 3/8"  
(Qty 3)



Washer 5/16"  
(Qty 2)

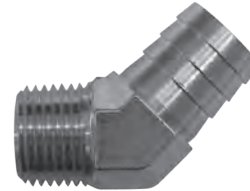

45° Fitting  
(Qty 1)



Compact Hex 3/8-16 x 1"  
(Qty 12)



Washer 3/8  
(Qty 12)



12 Pt Head 5/16-18 x 1.75"  
(Qty 8)



Washer 5/16  
(Qty 8)



Pulley Adapter  
(Qty 1)

1520, 1521, 15201, 15203, 15211 & 15213 Kits Only

1522, 1523, 15221, 15223, 15231 & 15233 Kits Only

## HARDWARE BAG 2

(parts not to scale)



Hex Flange M8 x 1.25 x 30mm  
(Qty 1)



Hex Flange M6 x 1.0 x 16mm  
(Qty 4)



Hex Flange M6 x 1.0 x 12mm  
(Qty 3)



3/4" Hose Clamp  
(Qty 8)



-12 AN Fittings  
(Qty 2)

# INTERCOOLER PLUMBING DIAGRAM

(parts not to scale)

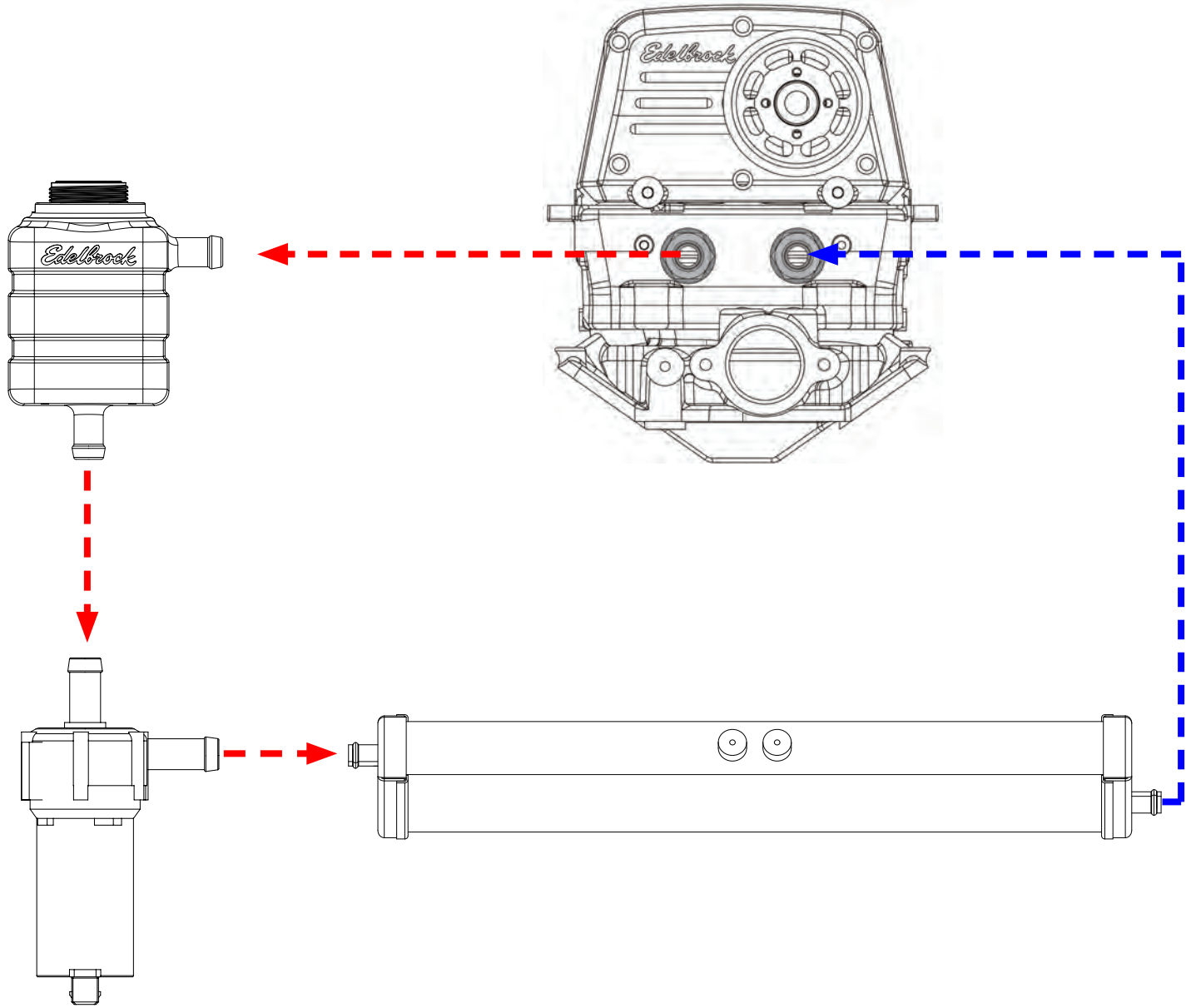



## **PARTS REMOVAL AND PREPARATION**

*These are general installation instructions for the Edelbrock Small Block Chevy Enforcer Supercharger. Removal and installation of factory components will differ from vehicle to vehicle. Please refer to your service manual for specific details on removal and installation of factory components if necessary.*

1. Disconnect the negative battery terminal.
2. Drain the radiator coolant (drain plug will normally be located on lower right of radiator, facing the engine).
3. Loosen the tension on the accessory belt(s) and remove belt(s). Remove the upper alternator tensioning bracket from the water pump.
4. Remove the crankshaft pulley bolts and remove the accessory pulley. Remove the crankshaft balancer bolt, but do not remove the balancer itself.
5. Remove the upper radiator hose, thermostat housing and thermostat, if mounted on the intake manifold.
6. Remove the gas cap to relieve fuel pressure. Disconnect the fuel line from carburetor and plug the fuel line to avoid excessive fuel drainage. Replace the gas cap.

**NOTE:** Take note of all factory linkage locations. This will simplify the installation process.

7. Disconnect all linkages from carburetor such as throttle, throttle springs, transmission, cruise control and automatic choke.
8. Tag and remove all coil wires, sensor wires, and vacuum lines. This will simplify the installation process.
9. Remove any brackets installed on the intake manifold.
10. Depending on application, removal of valve cover bolts and/or valve covers may be required. Replace any worn out valve cover gaskets to prevent oil leaks.

**CAUTION:** The following procedure must be followed carefully as serious damage to the engine can occur if the distributor is not removed and reinstalled correctly.

**NOTE:** This Edelbrock Enforcer Supercharger will not work with High Energy Ignition (HEI) Distributors.

11. Remove distributor cap. Note position of rotor and make a mark on the distributor case that lines up with the rotor point.

12. Note the position of distributor vacuum canister and place a mark on the valve cover (if applicable) or firewall that lines up with the vacuum outlet. **These marks will be used as a reference points when reinstalling the distributor.** However, re-alignment of the distributor may be required to clear the supercharger after installation.

13. Note the position of points (or magnetic trigger wheel). If open, how much; if closed, note the distance from point block to cam lobe (**See Figure 1**).

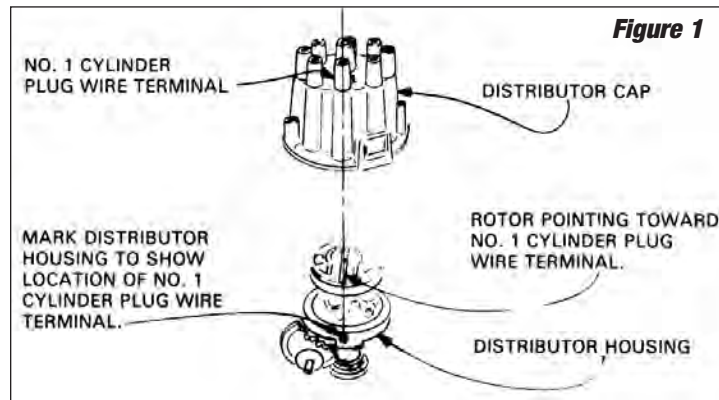

14. Remove the distributor from the engine. Once the distributor has been removed, DO NOT rotate the engine as this will throw off the engine's timing.

15. Remove the intake manifold bolts and remove the intake manifold along with the carburetor (if applicable).

16. Remove the factory mechanical fuel pump and push rod, clean mating surface on engine block with scraper and lacquer thinner.

**NOTE:** A fuel pump block-off plate (not included) is required to block-off the factory fuel pump hole.

17. Install block-off plate using the appropriate gasket and bolts.

18. THOROUGHLY clean the intake manifold bolt holes, cylinder head flanges, and end seal surfaces to remove all remaining gasket material and sealer.

**NOTE:** To prevent gasket material from falling into the ports and combustion chambers lay rags in lifter valley and stuff paper towels or rags into the ports.

19. Using a shop vac, vacuum all the debris from the lifter valley, mating surfaces, bolt holes, etc.

**NOTE:** Avoid using vacuums with metal tips as it can scratch the cylinder head surface. Also avoid using compressed air to blow the debris off as it can make its way into the block.

20. Once surfaces are clean, carefully remove all protective material from the ports and lifter valley. Using a rag and lacquer thinner, wipe down the gasket surfaces to remove any oil, grease or gasket residue.

## ENFORCER INSTALLATION PROCEDURE

1. Install the supercharger drive pulley in front of the factory crank pulley using the supplied 3/8-24 x 3.75" long hex head bolts and 3/8" washers (See Figure 2). Then install the supplied 7/16-20 x 2.75" balancer bolt with a 7/16" washer and snug the bolt down until the pulley is flush. **Do not torque down the bolts at this time.**



Figure 2

**NOTE:** Check replacement intake manifold gaskets (included) on the cylinder head surface and supercharger manifold to make sure they are correct. Beaded side of gasket faces up.

2. Apply two (2) thin layers of Gasegacinch (#9300) to the cylinder head's mating surfaces and on the bottom side of both manifold gaskets. Let the Gasegacinch tack up for about ten (10) minutes (See Figure 3).



Figure 3

3. Within a few minutes, the Gasegacinch will become tacky to the touch. Carefully place the supplied gaskets onto the head surface, aligning the ports and bolt holes (See Figure 4).

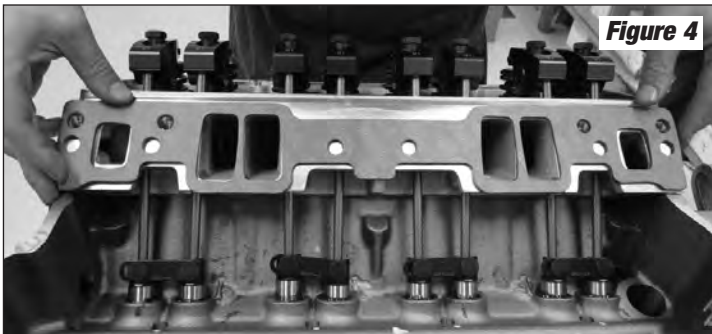

Figure 4

4. With the intake gaskets in place, apply a thin layer of silicone, with your finger, around the water passages on the intake manifold (See Figure 5).



Figure 5

5. Apply a 1/4" thick bead of silicone across each end seal surface (See Figure 6).



Figure 6

6. Carefully install the supercharger manifold onto the engine, making sure the bolt holes line up with the gaskets.

7. Loosely install the supplied manifold bolts and washers. Carefully move the supercharger to align the supercharger pulley to the crank pulley as best as possible. Torque all manifold bolts using the appropriate torquing sequence below.

**NOTE:** Crank pulley shims are provided for additional pulley adjustments. Crank pulley adjustments should be performed once the supercharger is securely torqued down.

**Edelbrock E-Tec/Vortec Applications** will be secured with eight (8) 12 point 5/16 x 1.75" bolts and 5/16" washers. Torque to 11 ft.-lbs (See Figure 7).

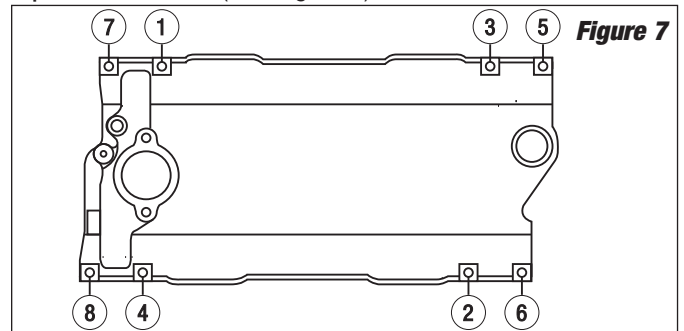
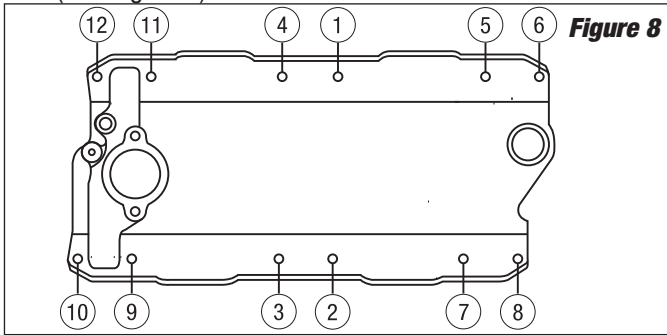

Figure 7

**1986 - Earlier Applications** will be secured with twelve (12) 3/8 x 1" Compact Hex bolts and 3/8" washers. Torque to 25 ft.-lbs (See Figure 8).



8. Using a straight edge, check to see if the supercharger pulley and the crank pulley have the proper offsets. If adjustments to the crank pulley is required, use the provided shims to adjust the offset of the crank pulley as needed. Once the crank pulley is properly aligned with the supercharger pulley, torque the balancer bolt to 60 ft./lbs and torque the pulley bolts to 32-35 ft./lbs.

9. Vehicles running the factory heater must remove the fitting on the water pump and replace it with the supplied 45° fitting. The factory fitting will not clear the supplied thermostat housing. To avoid water leaks, make sure to apply thread sealant onto the threads of the fitting prior to installation.

10. Using silicone and the factory bolts, install the thermostat, supplied thermostat housing and supplied thermostat housing gasket onto the supercharger manifold.

**NOTE:** The supplied thermostat housing will point towards the driver side. The thermostat housing was designed for radiators with upper driver side coolant returns. If you are using a radiator without an upper driver side coolant return, a different thermostat housing and/or upper radiator hose may be required to properly clear the supercharger.

11. Thread the 5/16-18 x 1" set screw into the provision on the front of the manifold next to the thermostat housing. Then install the Hex Spacer onto the set screw (See Figure 9).

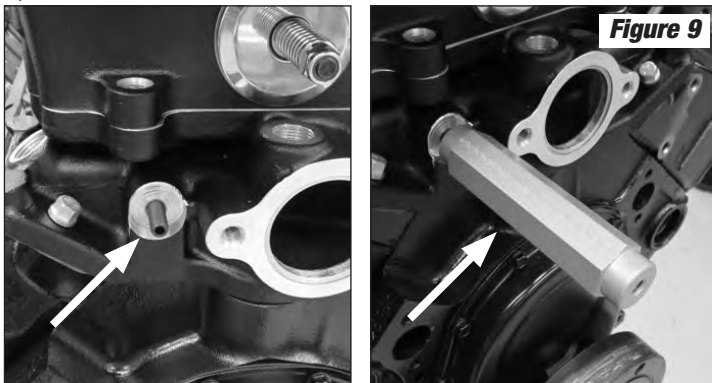

12. Using two (2) 5/16-18 x 3.5" SHCS bolts, install the FEAD bracket onto the supercharger housing (See Figure 10).

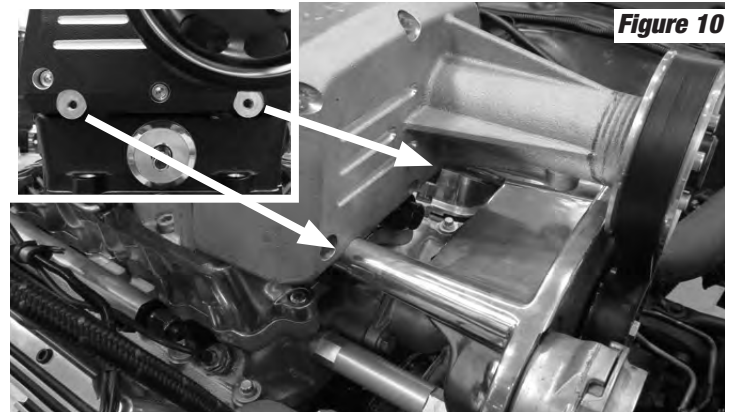

13. Place the supplied alternator bracket onto the lower provision of the FEAD bracket (where Hex Spacer is). Using one (1) 5/16-18 x 1.25" bolt and one (1) 5/16" washer, secure the alternator bracket and the FEAD bracket to the Hex Spacer. Then secure the alternator bracket to the alternator using the factory alternator bolt (See Figure 11).

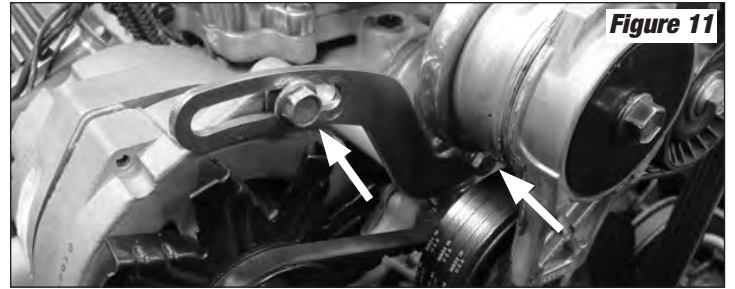

14. Install the accessory drive belt(s) and adjust the tension on the accessory belt(s) as needed. Reinstall any brackets that were attached to the intake manifold. Tighten all accessory bolts.

15. Using the one (1) 3/8-16 x 3.25" bolt, install the supplied belt tensioner to the left provision of the FEAD bracket and torque to 37 ft.-lbs. Place the Pulley Adapter onto the supplied idler pulley and install it onto the right provision of the FEAD bracket using one (1) 5/16-18 x 2" bolt and one (1) 5/16" washer; torque to 18 ft.-lbs (See Figure 12).

**NOTE:** The larger side of the Pulley Adapter must mount towards the FEAD bracket.

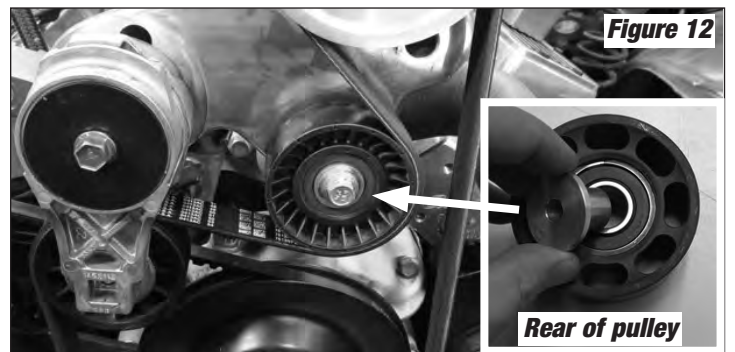

16. Install the supercharger drive belt using the belt routing diagram below (See Figure 13).

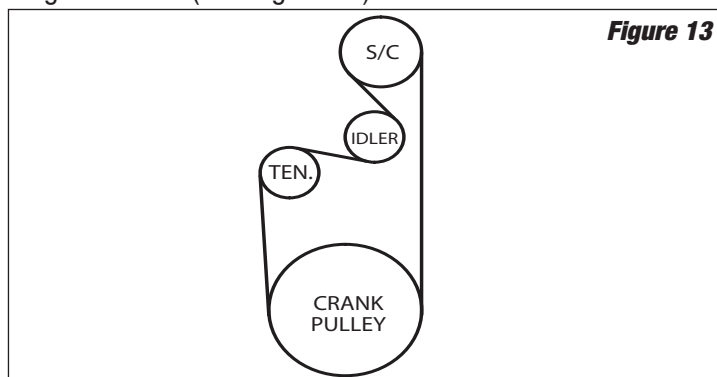

17. Reinstall the valve cover gaskets, valve covers and valve cover bolts if applicable.

18. Determine the best mounting location for the water pump. A universal mounting bracket has been supplied to simplify installation. Please note that the pump should be mounted no higher than the inlet of the heat exchanger. The inlet of the pump is in line with the axis of the pump motor, while the outlet extends out perpendicularly from the pump body.

19. Determine the best mounting location for the recovery tank reservoir. To simplify installation, a universal mounting bracket and a groove around the perimeter of the tank, for use with a large worm clamp (*not included*), have been included.

**NOTE:** Be sure to mount the tank as high as possible to prevent air bubbles from accumulating in the cooling system.

20. Determine the best mounting location for the intercooler heat exchanger (*sold separately*). It is important that the heat exchanger receives the coldest air possible, which means mounting it in front of the radiator, A/C condenser and any oil or trans cooler the vehicle might have equipped. Please check the Edelbrock website ([www.edelbrock.com](http://www.edelbrock.com)) for additional information on available intercooler heat exchangers.

21. Use the supplied 3/4" bulk hose, -12 AN Intercooler Fittings and the 3/4" hose clamps to plumb the intercooler system.

22. Refer to the Intercooler Plumbing Diagram on page 7 for the suggested intercooler plumbing. Note that the routing can also be inverted so that the pump and tank are mounted on the driver side. Regardless of component mounting locations, it is important that the correct direction of flow is maintained. The correct order, starting with the intercooler reservoir tank, is to have water flow as follows:

From the intercooler to the side fitting on the tank, the bottom fitting of the tank to the water pump inlet, the water pump outlet to the top of the heat exchanger, the bottom of the heat exchanger to the intercooler inlet.

23. Reinstall the distributor (See Figure 14). Make sure the distributor is aligned in the same position, with the rotor pointing to the same terminal as it was when the distributor was removed. You may need to lift and reinsert the distributor multiple times to align the rotor properly.



24. Remove the protective plastic covering the supercharger inlet, and install the throttle bodies using the supplied gaskets, 5/16" nuts and washers (*not included with 1520, 15201, 15203, 1522, 15221, 15223*).

**NOTE:** The supercharger will work with most, 4150-Style bolt pattern, throttle bodies. #1521, #1523, #15211, #15213, #15231 & #15233 systems include two Edelbrock #38783 throttle bodies and mounting hardware.

If using the Edelbrock Pro-Flo 2 EFI system, please refer to the Pro-Flo 2 instructions for details on throttle body installation.

25. Attach throttle linkage (*not included*) and verify it moves freely without interference (See Figure 16).

**NOTE:** Throttle linkages and rods are sold separately and may vary depending on your specific application.

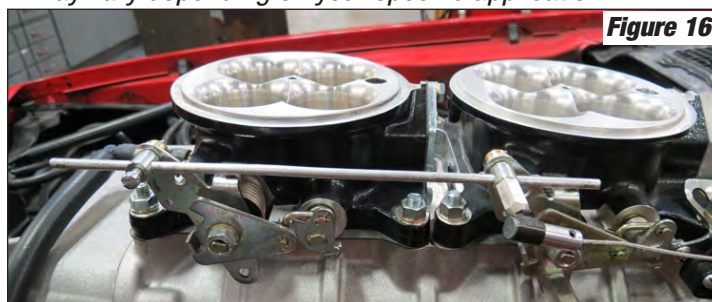

26. Move any sensors from the stock intake manifold to the Edelbrock supercharger manifold, and connect any wires. Connect vacuum lines, replacing with longer or shorter vacuum hoses as required.

27. Install the EFI electronics. Please refer to the EFI electronics' installation instructions for installation procedure.

28. Reinstall the upper radiator hose. A new upper radiator hose may be required as the factory one may run into the supercharger.

29. Replace the spark plugs with the recommended colder spark plugs (*2-3 heat ranges colder, see page 3*) and reconnect all ignition and spark plug wires. Make sure the spark plug wires are installed in the proper order.

30. Verify that the rotor in the distributor is pointing to the same location on the distributor housing as it was when removed. This should have been noted as described in the "Parts Removal and Preparation" section.

31. Top off all fluids to the appropriate factory recommended levels and reconnect the battery.

32. Verify that the installation of the EFI system is complete before proceeding.

33. Turn key to on position and check for any leaks that may be present. If leaks are found, turn the key off immediately and fix any leaks before continuing.

34. Start the engine and allow it to come up to operating temperature without revving the engine. Once engine is at operating temperature, it is highly recommended to set the ignition timing as described in the "**Boost and Ignition Timing**" section.

## **EFI SYSTEM RECOMMENDATIONS**

The following Edelbrock Pro-Flo 2 systems are specifically tuned for use with the Edelbrock Enforcer RPM Superchargers. These are included in #1521, 15211, 15213, 1523, 15231 and 15233 systems and are also available separately.

Pro-Flo 2	Description
P/N 35800	Pro-Flo 2, EFI Electronics for SBC TVS2300 Supercharger, Satin
P/N 35801	Pro-Flo 2, EFI Electronics for SBC TVS2300 Supercharger, Polished
P/N 35803	Pro-Flo 2, EFI Electronics for SBC TVS2300 Supercharger, Black

## **SUPERCHARGER PULLEY UPGRADE**

**10 RIB SUPERCHARGER PULLEY:** Additional supercharger pulleys are available for fine tuning air flow for your specific needs. These 10 rib supercharger pulleys are available in black and polished.

Polished P/N	Pulley Size	Black P/N	Pulley Size
15842	4.125	15845	4.125
15844	3.75	15848	3.75
15850	3.25	15851	3.25
15852	3.00	15853	3.00
15854	2.75	15855	2.75